



CHAMPION VALVES INC.

SINGLE DISC SPRING LOADED WAFER CHECK VALVES

CHAMPION WAFER CHECK VALVES · SIZE RANGE 2" - 24" · ASME CLASS 125 - 900



INTERNAL SPRING DESIGN · TRADITIONAL & RETAINERLESS STYLE VALVE BODIES



FEATURES & BENEFITS

Champion Valves Inc.'s single disc wafer check valves are designed for installation in flanged piping systems in both horizontal and vertical orientations. Compatible with applications such as gaseous compressors and blowers, water and oil pumps, and biofuels production. CVI's model SD & SDR provides uni-directional protection among a wide variety of services.



Low weight design
80% - 90% weight reduction compared to full body swing check valves



Versatile functionality for horizontal and vertical installations



Integrated single piece cast disc and arm assembly increases unit integrity



Simplifies piping, optimizes space utilization, and lowers installation costs



Simple in-field reparability to mitigate downtime



Traditional and zero fugitive emission designs available

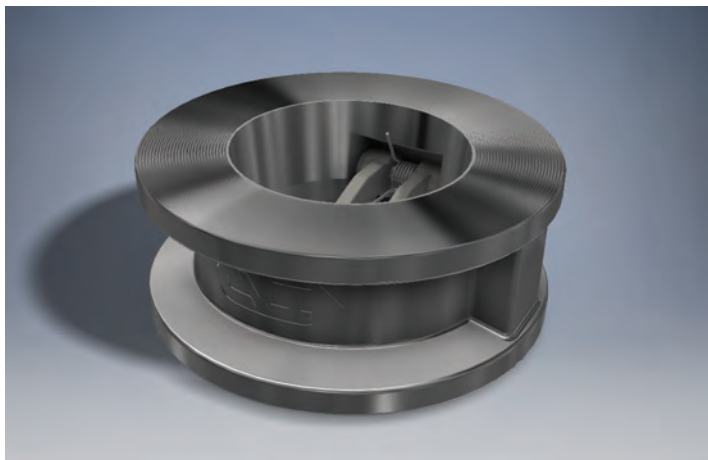

RATING & DIMENSIONS

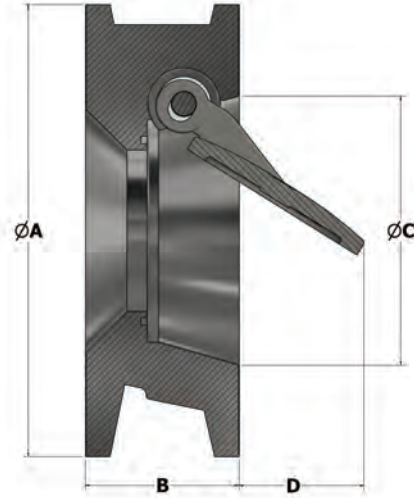

ASME CLASS 125 & 150

Size <i>in</i>	A <i>in</i>	B <i>in</i>	C <i>in</i>	D <i>in</i>	Cv <i>GPM</i>
2	4.125	1.750	2.063	0.813	70
2.5	4.875	1.875	2.938	1.063	190
3	5.375	2.000	3.063	1.625	225
4	6.875	2.250	4.063	2.250	295
5	7.750	2.500	5.063	3.000	430
6	8.750	2.750	6.063	3.750	700
8	11.000	2.875	7.938	4.594	1270
10	13.375	3.125	10.000	6.438	2350
12	16.125	3.500	12.000	8.125	3850
14	17.750	4.250	13.250	6.750	4250
16	20.250	4.250	15.250	7.969	7000
18	21.625	4.250	17.250	9.375	9550
20	23.875	5.500	19.250	11.438	13000
24	28.250	6.000	23.250	15.000	25000

ASME CLASS 300

Size <i>in</i>	A <i>in</i>	B <i>in</i>	C <i>in</i>	D <i>in</i>	Cv <i>GPM</i>
2	4.375	1.750	2.063	0.813	70
2.5	5.125	1.875	2.938	1.063	190
3	5.875	2.000	3.063	1.625	225
4	7.125	2.250	4.063	2.250	295
5	8.500	2.500	5.063	3.000	430
6	9.875	2.750	6.063	3.750	700
8	12.125	2.875	7.938	4.594	1270
10	14.250	3.125	10.000	6.438	2350
12	16.625	3.500	12.000	8.125	3850

* Apply with factory for certified drawings. Cracking pressure and weights available upon request.

MODEL SD & SDR FIGURE NUMBER INFORMATION

Order Example : Specifications call for 6" Champion Valves Inc. Single Disc Wafer Check Valve Model SD, ASME 150, 316 Stainless Steel Body with 316 Stainless Steel Disc; PTFE Seat; 316 Stainless Steel Spring, RF Finish

SIZE	MODEL	PRESSURE CLASS	BODY	DISC	SEAT	SPRING	END CONNECTION	MODIFICATION
6	SD	15	S	S	T	S	R	

SIZE	ORDER SYMBOL
2"	2
2.5"	2.5
3"	3
4"	4
5"	5
6"	6
8"	8
10"	10
12"	12
14"	14
16"	16
18"	18
20"	20
24"	24

PRESSURE CLASS	ORDER SYMBOL
ASME 125	12
ASME 150	15
ASME 300	30
ASME 600	60

BODY	ORDER SYMBOL	SPECIFICATION
Ductile Iron	L	ASTM A395 60-40-18
Carbon Steel	C	ASTM A216 WCB
316 SS	S	ASTM A351 CF8M

DISC	ORDER SYMBOL	SPECIFICATION
304 SS	T	ASTM A351 CF8
316 SS	S	ASTM A351 CF8M

SEAT	ORDER SYMBOL	TEMPERATURE	
		°F MIN	°F MAX
Buna	B	-70	250
EPDM	E	0	300
Viton	V	-40	400
PTFE	T	-40	300
Integral Metal	P	-450	1000+
316SS	S	-450	1000+

SPRING	ORDER SYMBOL
316 SS	S
Inconel X-750	X

END CONNECTION	ORDER SYMBOL
Plain Face	P
Raised Face	R

MODEL	ORDER SYMBOL
SD	SD
SD Retainerless	SDR

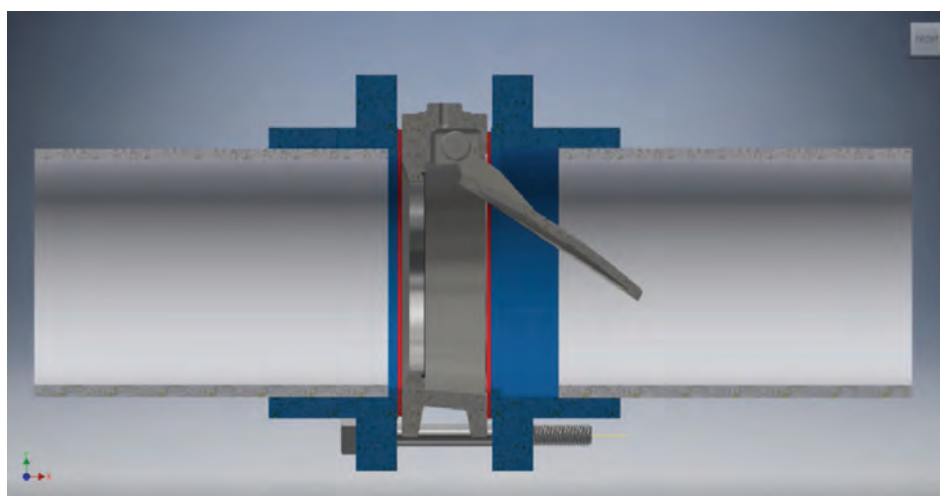

QUALITY SYSTEM

Champion Valves, Inc. is dedicated to the goal of total quality management to provide industry-best valve construction and support services.





CHAMPION VALVES INC.
COMMITMENT **VALUE** INNOVATION

P.O. BOX 12901 WILMINGTON, NC 28405, USA
PHONE: 910-794-5547 FAX: 910-794-5581

EMAIL: SALES@WAFERCHECK.COM

WWW.WAFERCHECK.COM

PROUD MEMBER :

